



02 9452-3566

sales@getpacked.com.au

PALLET STRETCH WRAPPING MACHINE

MODEL: 1-GPEXP-403L Low Profile Pallet Wrapper

OPERATION MANUAL



TABLE OF CONTENT

1. GENERAL INFORMATION.....	3
1.1 NOTE OF INSTALLATION	3
1.2 NOTICE OF OPERATION.....	4
2. SPECIFICATION	5
2.1 SPEC. TABLE	5
2.2 MACHINE DIMENSION	6
2.3 MACHINE DESCRIPTION	7
3. OPERATION DESCRIPTION	8
3.1 INSTALLATION.....	8
3.2 REMINDER OF INSTALLATION	9
3.3 OPERATION OF CONTROL PANEL.....	12
3.4 OPERATION DESCRIPTION.....	12
4. ELECTRICAL	13
4.1 ELECTRICAL CAPACITY	13
4.2 ELECTRICAL DIAGRAM	14
5. TROUBLE SHOOTING	26
5.1 GENERAL ADJUSTMENT	26
5.2 TROUBLE SHOOTING WITH EXP-403L MACHINE.....	27
6. PART LIST.....	28
6.1 SEAT	28
6.2 TOWER	30
6.3 CARRIAGE.....	33

1. GENERAL INFORMATION

1.1 NOTE OF INSTALLATION

To make sure a safe and correct operation, please check below conditions before install the machine:

- 1) Power source capacity must be equal of the machine need.
- 2) Machine standard power is 110v/220v (+- 10%)
- 3) Machine standard power Hertz is 50/60 Hz. (+- 2%)
- 4) Machine is workable under the temperature between 0°C - 45°C
- 5) Make sure the wire is tidy on the ground.
- 6) There should not have vibration beside the machine during the installation, and make sure the ground is flat.
- 7) Read and follow the instruction of the installation.

1.2 NOTICE OF OPERATION

To have good protection for the operator, please make sure the following conditions:

- 1) Before operating, please read the machine operational manual carefully.
- 2) Make sure there is no object put on the power cable.
- 3) Make sure there is no object put on the upper carriage unit.
- 4) Avoid any damp object or water around the electric parts.
- 5) Avoid film winded into the turntable.
- 6) Do not stand on or across the machine during operation.
- 7) When problem occurs, please check Section 5 Trouble Shooting

2. SPECIFICATION

2.1 SPEC. TABLE

Model	EXP-403L
Turntable Speed	Adjustable 2.5 ~ 10 RPM
Turntable Diameter	1650mm
Max. Wrapping Height	2200mm
Pallet Size	1050x1050mm
Max. Loading Weight	1200kgs
Film Stretch (%)	Manually adjustable
Carriage Unit Speed	Fixed 3.3m/min
Max. Film Spec.	φ250x500mm
Turntable Height	31mm
Machine Size	2634x1650x2561mm
Machine Net Weight	458kg

Standard option:

- ❖ 2.6 & 3.0 meters wrapping height
- ❖ Ramp

2.2 MACHINE DIMENSION

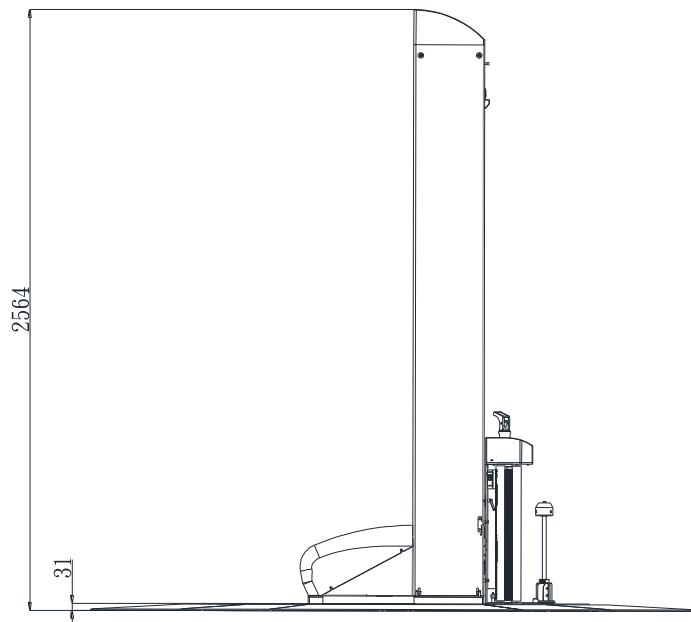
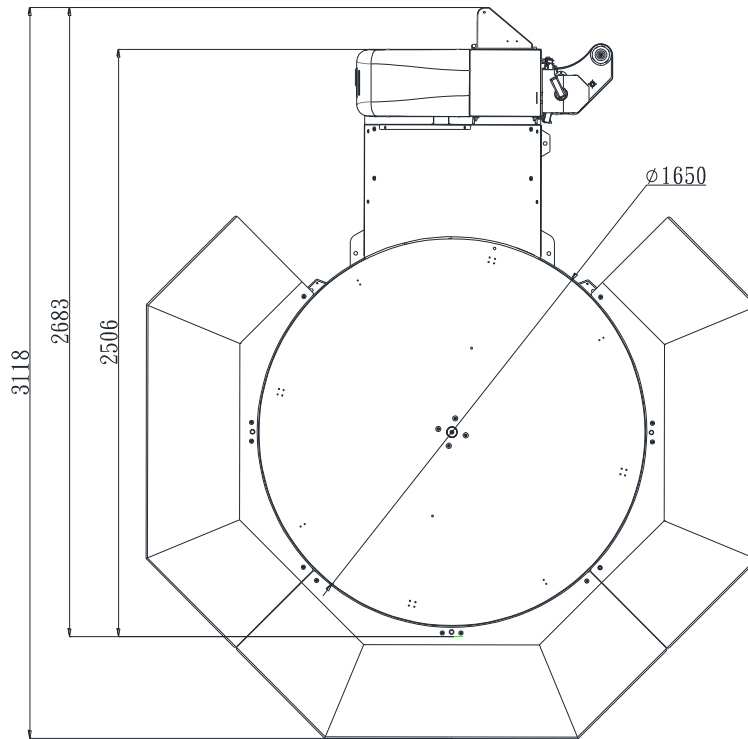

2.3 MACHINE DESCRIPTION

