



02 9452-3566

sales@getpacked.com.au

USER MANUAL PALLET STRETCH WRAPPER

IM 315



TABLE OF CONTENT

1.	Technical Data	Page 1
2.	Installation	Page 2
3.	Control Panel	Page 4
4.	Usage	Page 11
5.	Test Machine Steps	Page 13
6.	Maintenance	Page 14
7.	Additional Instructions	Page 14
8.	Mechanical Spare Parts List	Page 17
9.	Warranty	Page 28
10.	Safe Operating Guidelines	Page 30
11.	Testing and Tagging	Page 31

General Information

1. Technical Data

1.1. Standard Pallet Dimension:

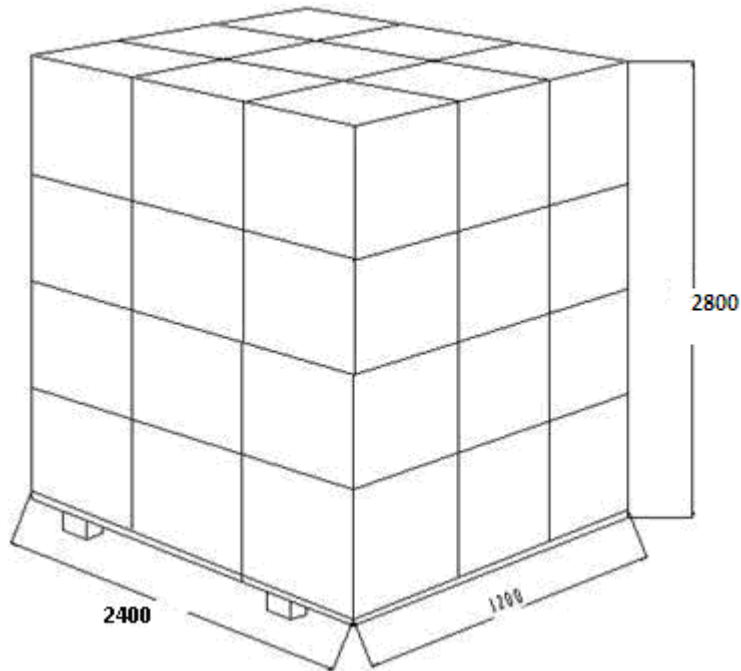

All units are in millimeters (mm)

1.2 Turntable Capacity 2000Kg(max)

Maximum weight of the load should not exceed 2000kg.

If load limit exceeds, then machine's life span will be shortened.

1.3 Power Supply (AUS Standard): AC 240V 50HZ 20A -1P

1.4 Power: 1.2 kW

1.5 Turntable speed: 0~15rpm

1.6 Turntable diameter : 1650mm

1.7 Machine Weight

600Kg

1.8 Packing Materials

Material	stretch film
Width	450 / 515mm
Thickness	8-35μm
Inner Core	76.2mm
Outer-Dia.	\leq240 mm

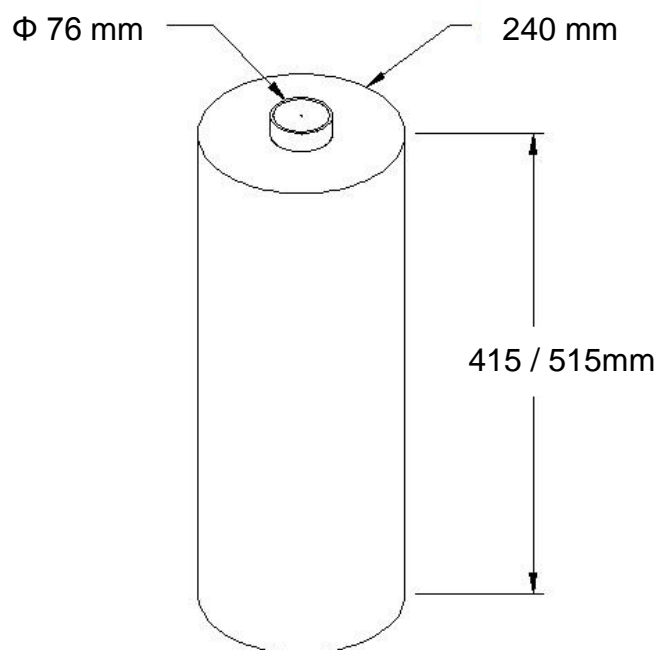

2. Installation

2.1 Installation work must be carried out by the qualified technicians.

2.2 Please use the suitable transportation means, when moving the machine to its installation location.

Forklift Tube



2.3 Minimum safety clearance for machine installation.

Min. distance between wall and the machine should be 1000mm ~ 1 meter

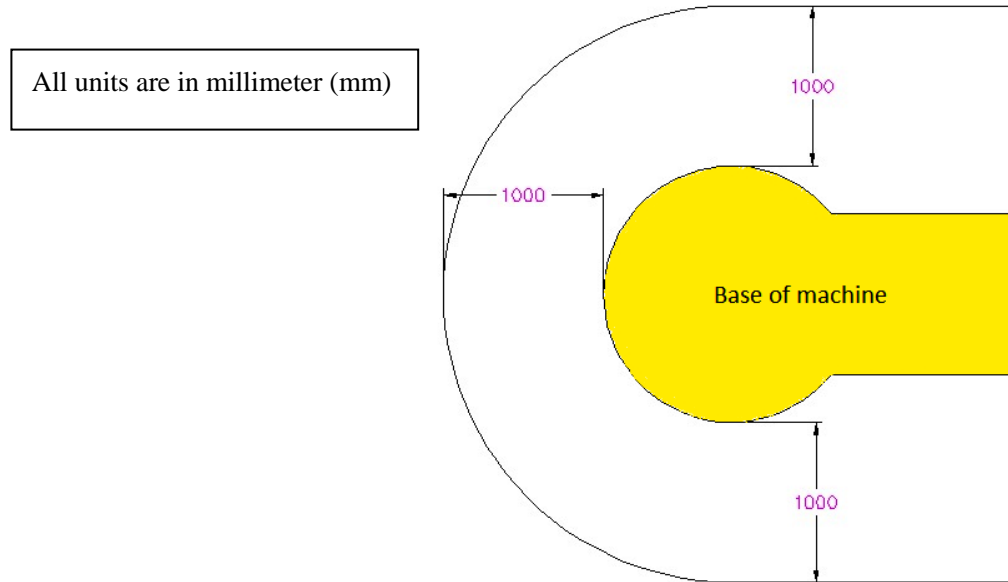

2.4. This machine should be installed in a dry and clean place where there will be no dust, no leakage, and no chemical preparation of flammable, explosive or other corroding chemicals.

The surrounding temperature should be in a range from -10°C to 50°C .

2.5 Mechanical parts assembly

2.5.1 Place the machine on a level floor.

2.5.2 Install the ramp on the same level as the machine.

Make sure that there will be enough space for forklift to run on ramp safely.

3. Control Panel:

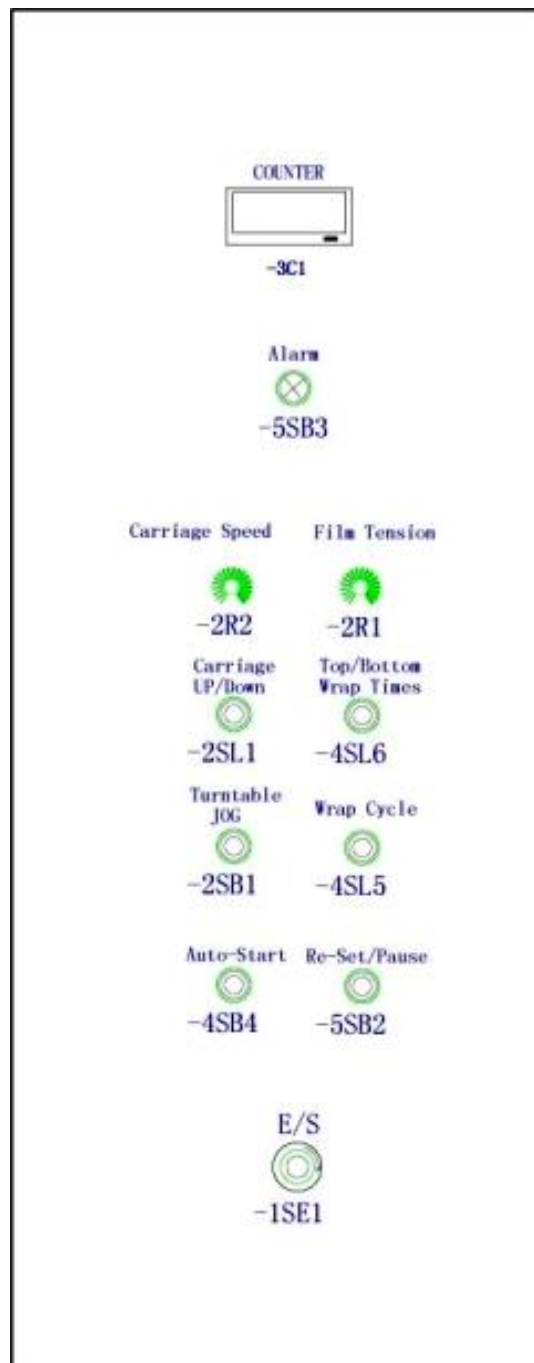

Control Panel Operation

Please refer to Picture of the Operating Panel

1. **Film Tension:** This adjustable pot allows adjusting the film tension manually. Markings on the pot will allow you to set the desired film tension.
Customer will adjust the tension to obtain the desired film tension suited for their product.

2. **Pause/Reset:**
 - 1) Press the Pause/Reset button to reset the machine so that film carriage or turntable will reset to home position.
 - 2) By pressing the Pause/Reset button during Auto-start mode, the machine will be paused.
By pressing Auto-start button again to restart the cycle (while the machine is at pause position) the turntable will take approximately 2 turns before the carriage raises or lowers to complete the cycle.

3. **Auto-Start:** After setting film carriage and turn table to its home position, press Auto-start button to start wrapping.

4. **Emergency Stop:** Emergency Stop is a Push-Pull, self-lock button.
Push in to lock and rotate clockwise to release.
When the button is pushed in, the machine will stop immediately.

Note!

After the Emergency Stop Button has been pressed in, wait for one minute before releasing the button. This time will allow the electrical components to reset.

If the machine does not restart after the Emergency Stop Button has been released, then turn the machine off for one minute and then restart it.

5. Carriage up/ down:

In stop condition of machine, this switch allows the film carriage to be raised or lowered manually. While continuing to hold the switch left the film carriage will raise until the carriage strikes top limit block and stops.

While continuing to hold the switch right the film carriage will lower until the carriage strikes to bottom limit block and stops.

6. Carriage speed:

This adjustable pot allows adjusting the speed of carriage manually. Markings on the Carriage speed pot will allow you to set the desired carriage speed.

Customer will adjust the carriage speed to obtain the desired film overlap suited for their product.

7. Turntable jog:

In stop condition of machine, the turntable jog button allows the turntable to be manually rotated.

8. **Alarm:** The alarm light will illuminate to indicate that a service is required on the machine.
The service frequency is set to 10,000 cycles.
Call the service agent to service the machine when machine is about to complete 10,000 cycles.
9. **Counter:** The counter is a permanent record of how many cycles the machine has completed.
10. **Top / Bottom Wrap Times:** This allows the operator to select the number of wrap at the top & bottom of the product. (eg:1 represent “top & bottom wrap one time”, 2 represents “top & bottom” wrap two times & 3 represents “top &bottom ” wrap three times).
11. **Wrap cycle:** There are three wrap cycles.

When the toggle switch is “**ON**”, means we set the machine to wrap the top of the load in last. The wrap cycle will wrap the load as follows:

Note: Toggle Switch should be operated by authorized personnel only.

1= One Way Wrap

Set the Wrap Cycle to 1 by using Wrap Cycle switch on control panel, then press the Auto Start push button; once pushed, the turntable will start to rotate and ramping up to the set point speed. The turntable will continue to rotate and count the bottom wraps once the bottom wraps have been counted the carriage will begin to move up according to carriage up speed that has been set. Unless the Photo Electric sensor senses the top of the load, the carriage will continue to move up, once Photo Electric senses the top, for time duration,

the carriage will stop moving further up. The turntable will continue to rotate and count the top wraps, once top wraps have been counted the turntable ramps down and stops in the home position. Press the Reset button to return the carriage down to the home position – Cycle complete.

2= Two Way Wrap

Set the Wrap Cycle to 2 by using Wrap Cycle switch on control panel, then press the Auto Start push button; as the machine is set to wrap the top part of the load in last, the turntable will start to rotate and ramping up to the set point speed. The turntable will continue to rotate and count the bottom wraps once the bottom wraps have been counted the carriage will begin to move up according to carriage up speed that has been set. Unless the Photo Electric sensor senses the top of the load, the carriage will continue to move up, once Photo Electric senses the top, for time duration, the carriage will stop moving further up. The turntable will continue to rotate and count the top wraps, once top wraps have been counted the carriage begins to move down according to carriage down speed that has been set. Once the carriage stops at the home position, turntable then ramps down and stops in the home position – Cycle complete.

3= Two Way Wrap with stop at top for top sheet application

Set the Wrap Cycle to 3 by using Wrap Cycle switch on control panel, then press the Auto Start push button ; as the machine is set to wrap the top part of the load in last, the turntable will start to rotate and ramping up to the set point speed. The turntable will continue to rotate and count the bottom wraps, once the bottom wraps have been counted the carriage will begin to move up according to carriage up speed that has been set. Unless the Photo Electric sensor senses the top of the load, the carriage will continue to move up, once Photo Electric senses the top, for time duration, the carriage will stop moving

further up. The turntable will ramp down and stops at the home position. Now place the top sheet over the load. When top sheet placed, press the Auto-start button again; the turntable will start to rotate and ramping up to the set point speed. The turntable will continue to rotate and count the top wraps, once the top wraps have been counted the carriage will begin to move down according to carriage down speed. Once the carriage stops at bottom, turntable then ramps down and stops in the home position – Cycle complete.

When the toggle switch is “**OFF**”, means we set the machine to wrap the top of the load first. The wrap cycle will wrap the load as follows::

Note: Toggle Switch should be operated by authorized personnel only.

1= One Way Wrap

Set the Wrap Cycle to 1 by using Wrap Cycle switch on control panel, then press the Auto Start push button; once pushed, the turntable will start to rotate and ramping up to the set point speed. The turntable will continue to rotate and count the bottom wraps once the bottom wraps have been counted the carriage will begin to move up according to carriage up speed that has been set. Unless the Photo Electric sensor senses the top of the load, the carriage will continue to move up, once Photo Electric senses the top, for time duration, the carriage will stop moving further up. The turntable will continue to rotate and count the top wraps, once top wraps have been counted the turntable ramps down and stops in the home position. Press the Reset button to return the carriage down to the home position – Cycle complete.

2= Two Way Wrap

Set the Wrap Cycle to 2 by using Wrap Cycle switch on control panel, then press the Auto Start push button; as the machine is set to wrap the top part of the load first, the turntable will start to rotate and ramping up to the set point

speed. As the turntable attains its set speed, the carriage will begin to move up according to the carriage speed that has been set. Unless the Photo Electric sensor senses the top of the load, the carriage will continue to move up, once Photo Electric senses the top, for time duration, the carriage will stop moving further up. The turntable will continue to rotate and count the top wraps, once top wraps have been counted the carriage begins to move down according to carriage down speed that has been set. Once the carriage stops at the bottom, The turntable will continue to rotate and count the bottom wraps once the bottom wraps have been counted turntable then ramps down and stops in the home position - Cycle complete.

3= Two Way Wrap with stop at top for top sheet application

Set the Wrap Cycle to 3 by using Wrap Cycle switch on control panel, then press the Auto Start push button; as the machine is set to wrap the top part of the load first, the turntable will start to rotate and ramping up to the set point speed. As the turntable attains its set speed, the carriage will begin to move up according to the carriage speed that has been set. Unless the Photo Electric sensor senses the top of the load, the carriage will continue to move up, once Photo Electric senses the top, for time duration, the carriage will stop moving further up. The turntable will ramp down and stops at home position. Now place the top sheet over the load. When top sheet placed, press the Auto-start button again, the turntable will start to rotate and ramping up to the set point speed. The turntable will continue to rotate and count the top wraps, once top wraps have been counted the carriage begins to move down according to carriage down speed that has been set. Once the carriage stops at the bottom, The turntable will continue to rotate and count the bottom wraps once the bottom wraps have been counted turntable then ramps down and stops in the home position - Cycle complete.

4. Usage

4.1 Loading the film roll

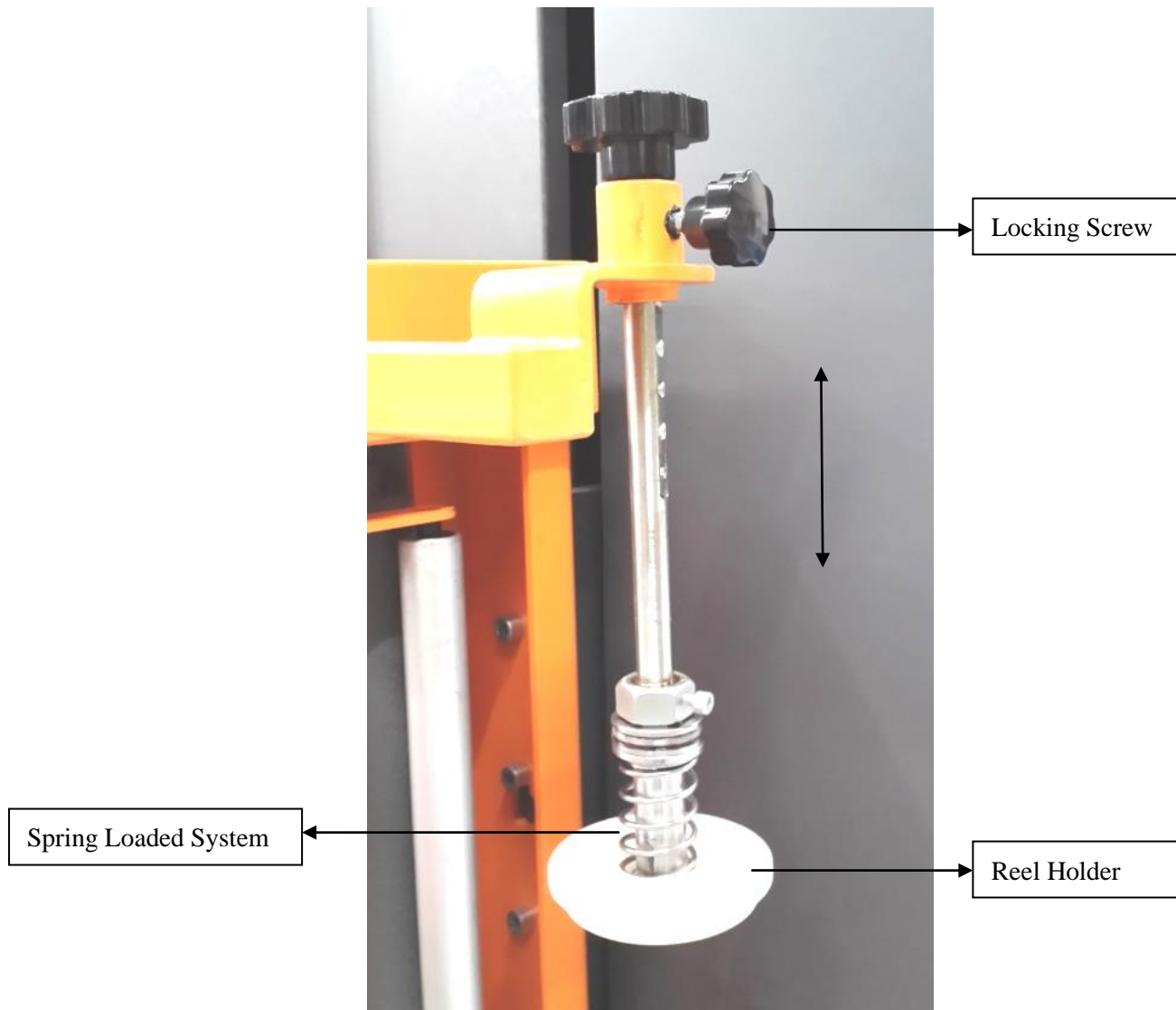

4.1.1 Back off the locking screw and raise the spring load system.

4.1.2 Place the film on the reel holder.

4.1.3 Push down the spring load system and tighten the locking screw.

4.2 Threading Film in Stretch Unit:

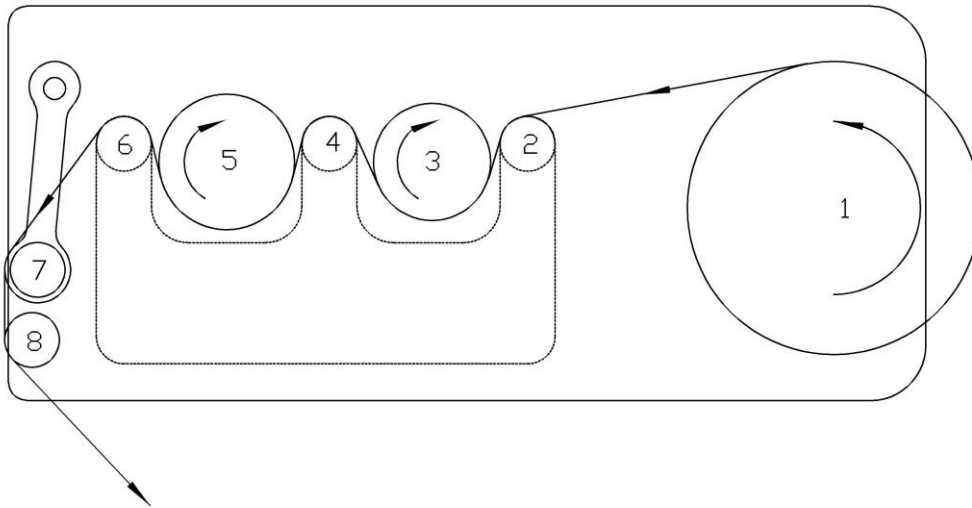

- 1 Film roll 2,4,6 Door guiding roller 3,5 Rubber roller 7 Dancer arm 8 Guiding roller

4.2.1 Place the film roll on the reel holder with the film coming off the back of the reel.

4.2.2 Pull out approximately one meter of film and pass it in front of the guiding rollers , then behind the rubber rollers as shown in above figure.

4.2.3 Pull the length of film from the stretch unit and attach to the pallet.

Note: Always pull the film smoothly from the stretch unit. Do not tug with excessive force.

4.3 Load height detection

The photo electric eye is fitted to the film carriage that will automatically detect the height of the load. There are also manually adjustable limit blocks, which defines the top and bottom height to photo-electric eye.

5. Test Machine Steps

Before starting the wrap test and load set-up, make sure that you have read and understood the manual and familiar with all the functions of this machine. After the machine has been correctly installed in its designated operating location and is ready for initial testing, please follow these steps before wrapping.

- Step 1 Turn on the power, make sure Emergency Stop is released.
- Step 2 Test the turntable by activating the Turntable jog switch. Check if the turntable is running correctly. If there is no problem, continue to jog the turntable around until it is back to its designated home position.
- Step 3 Manually operate the film carriage up. Make sure the direction is correct, and that the limit switch stops the carriage.
- Step 4 Manually operate the film carriage down, Make sure the direction is correct, and that the limit switch stops the carriage.
- Step 5 Load the film roll and thread the film to make sure the film stretch unit is operating correctly (See notes on threading the film).
- Step 6 Attach the film at the bottom of the load.
- Step 7 Set the desired number of Top wraps, Bottom Wraps & Wrap Cycle.
- Step 8 Press the Auto-start button and check the machine operation.
Note: The machine will not start if the film carriage is off home position. Press Reset/Pause button to set film carriage to its home position.

Step 9 If all is correct, you may now begin wrapping your products. Please refer to the appropriate sections of this manual for any changes to any settings.

6. Maintenance

It is recommended that all service work is carried out by an Integrated Machinery's authorized service technician.

Before undertaking any maintenance job, make sure that the power is **OFF and unplugged.**

6.1 Periodically apply grease to: The turntable and carriage chains. If the film carriage wobbles during the up & down process, the chain shall require tensioning.

6.2 If the turntable chain is loose, remove turntable motor cover, loosen the four bolts on the mounting plate and adjust tensioning screw until you achieve the required tension. Tighten bolts on the mounting plate and replace turntable motor cover.

7. Additional Instructions

7.1 Turntable

In the first auto-start process, if the turntable is not at the home position, the machine will start running, but the turntable will stop at the home position after the wrap is finished.

7.2 Limiting Block

The limiting block is clamped by the cap head screw and can be moved between the upper fixed location-limiting block and the lower one to meet the requirements of the client when the function of the height-measuring photoelectric eye is contained.

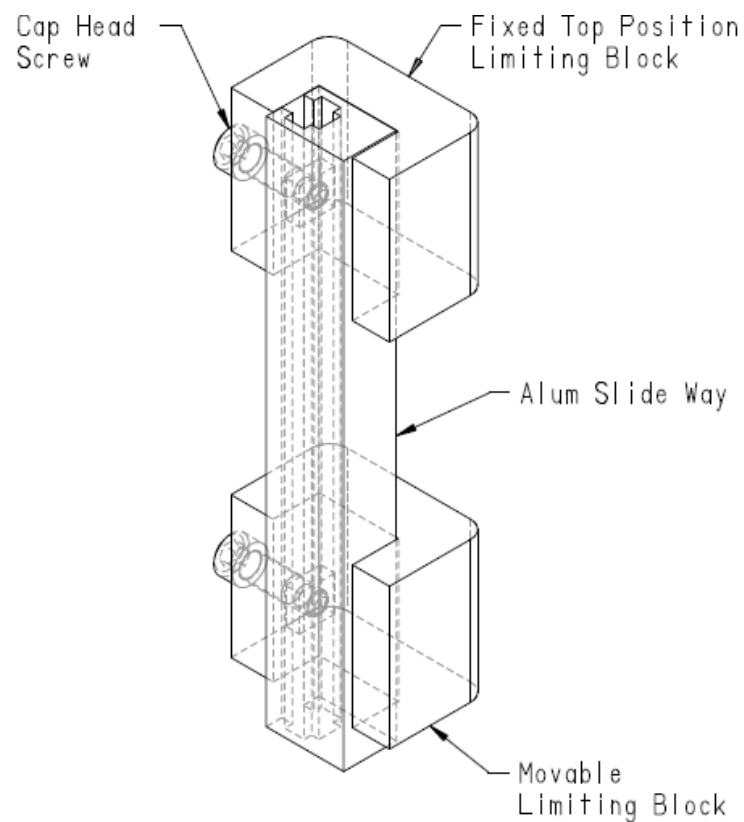

7.3 Photo-Eye

The photo eye will be ineffective under following circumstances;

- a) the sun or halogen lights,
- b) and if the goods are colored glass items
- c) also items with low reflection Black,
- d) items with large space between their components and transparent items,

In these conditions, the photoelectric eye should be adjusted in accordance with the methods described later. If described method does not work, then use the spare location-limiting block, the effect of using spare location-limiting block will be same as or even better than that of the height-measuring by the photo eye.

The photo eye has already been adjusted prior to leaving the manufacturer; it also can be re-adjusted in case of the following:

If the photo eye cannot sense and measure the goods, adjust the direction of the eye properly until the eye senses the center of the goods. If this method does not work, open the cover of the photoelectric eye to adjust the sensing and measuring distances. Turn the Sensitivity adjustor clockwise towards MAX until the eye senses and measures soundly.

A red LED will illuminate when the photo eye senses the product.

8. Mechanical Spare Parts List

8.1 Film Head Drawing

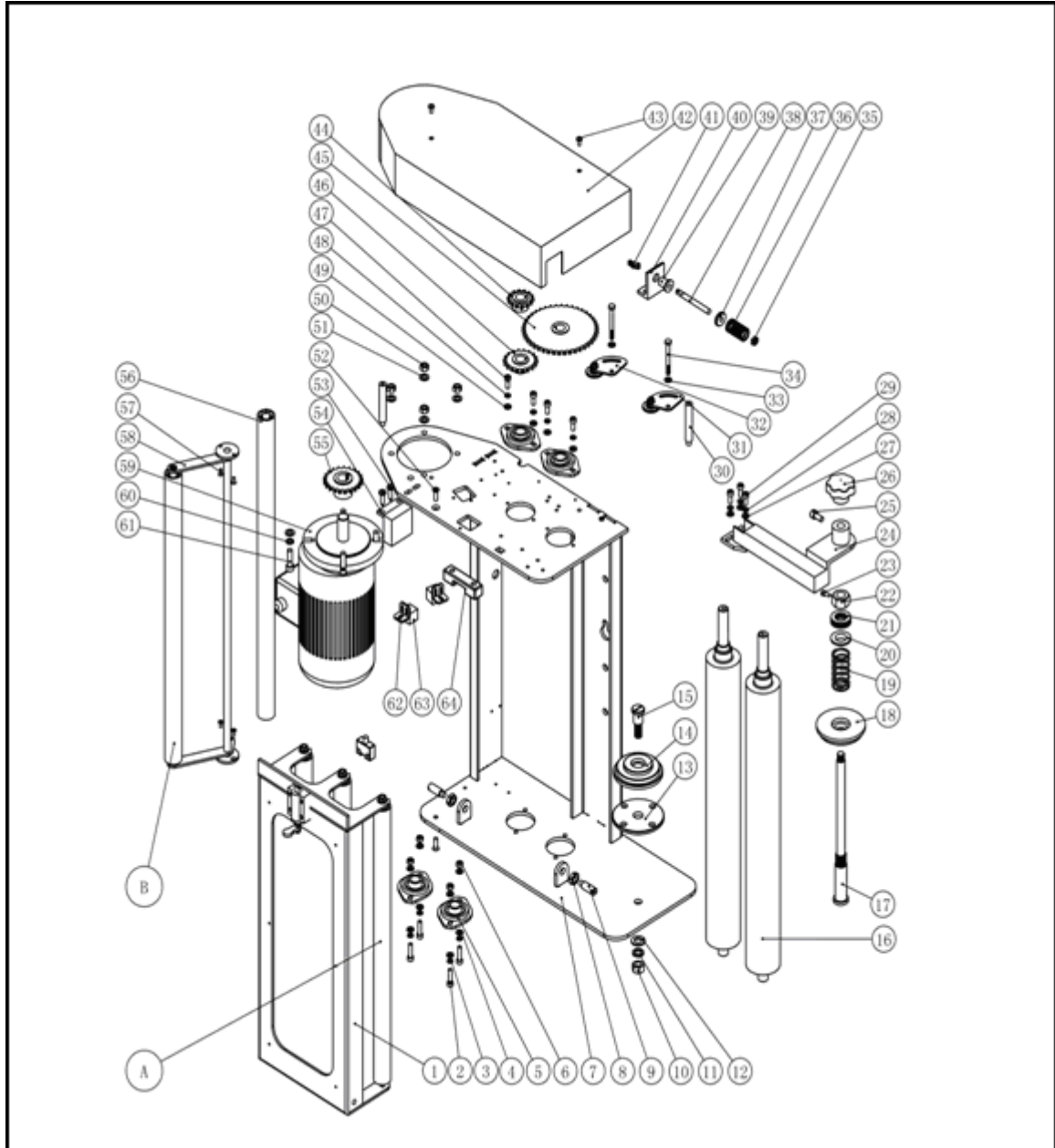

Film Head Parts List SMIP0P

No	Part No.	ERP	Description	Qty
1	01300618	SM010J07	Door ASSY	1
2	----	GB/T 70.1-2000.M6x25	M6x25 Hex socket head screw	12
3	----	GB/T 93-1987.6	6mm Spring washer	10

4	----	GB/T 95-2002.6	6mm Flat washer	10
5	01300619	GB/T 7810-1995	Ball bearing CL90203	4
6	----	GB/T 41-2000.M6	M6 Nut	7
7	01300620	SMIP0J01	Film head frame weld	1
8	01300621	GB/T6172.1-2000.M12	M12 Hex nut	2
9	01300622	GB/T 75-1985.M12x35	M12x35 Slotted head screw	2
10	01300503	GB/T 41-2000.M12	M12 Nut	1
11	01300504	GB/T 93-1987.12	12mm Spring washer	1
12	01300505	GB/T 95-2002.12	12mm Flat washer	1
13	01300446	SM010A20	Wear plate	1
14	01300506	SMIP0J03	Film holder bottom seat	1
15	01300507	SM010A18	Location screw	1
16	01300525	SM010A11	Brake roller	2
17	01300502	SM010A14	Adjusting bolt	1
18	01300508	SMIP0J02	Film Holder top seat	1
19	01300510	SM010A16	Clamp spring	1
20	01300509	SM010A15	Spring location sleeve	1
21	01300171	GB/T 301-1995	Thrust ball bearing 51104	1
22	01300512	GB/T 41-2000.M18	M18 Nut	1
23	----	GB/T 70.1-2000.M5x10	M5x10 Hex socket head screw	1
24	01300623	SMLS0A06	Film arm top support	1
25	01300064	CM8X32X16	Brake Knob handle	1
26	01300309	CM12X50	Star grip knob	1
27	----	GB/T 95-2002.6	6mm Flat washer	3
28	----	GB/T 93-1987.6	6mm Spring washer	3
29	----	GB/T 70.1-2000.M6X25	M6x25 Hex socket head screw	3
30	01300518	SM010J12	Guard spacer	2
31	01300175	SM010J17	Chain idler wheel assy	1
32	01300175	SM010J18	Chain idler wheel assy	1
33	----	GB/T 95-2002.6	6mm Flat washer	2
34	----	GB/T 70.1-2000.M6x35	M6x35 Hex socket head screw	2
35	----	GB/T 41-2000.M8	M8 Nut	1
36	01300624	SM010A29	Dancer-arm spring	1
37	01300625	SM010A27	Locating Nut	1
38	01300626	SM010A28	Threaded shaft	1
39	01300627	SM010A30	Pivot guide sleeve	1
40	01300628	SM010A31	Pivot mounting plate	1
41	01300629	GB/T1243-1997	Chain 06B	1
42	01300630	SMIP0J04	Film head cover	1
43	----	GB/T 818-2000.M5X8	M5x8 Cross pan head screw-H type	4
44	01300631	SMIP0F09-12T	Stretch Roller bossed sprocket(1:3)	1
45	01300632	SMIP0C04	Idler roller sprocket(1:3)	1

46	01300633	SM030A18	Gearbox drive sprocket	1
47	----	GB/T 70.1-2000.M6x16	M6x16 Hex socket head screw	9
48	----	GB/T 93-1987.6	6mm Spring washer	9
49	----	GB/T 95-2002.6	6mm Flat washer	4
50	----	GB/T 41-2000.M8	M8 Nut	2
51	----	GB/T 95-2002.6	6mm Flat washer	8
52	----	GB/T819.2-2000.M6X20	M6x20 cross sunk head screw	4
53	----	GB 818-1976.M6x25	M6X25 cross pan head screw	2
54	01300501	PTK-5555-320-20-JW	Photo eye	1
			T06B1-25H&1210-20 gearbox drive sprocket &taper sleeve	
55	000281	SMIP0C02		1
56	01300526	SM010J06	Guiding roller	1
57	----	GB/T819.2-2000.M4X10	M4x10 cross sunk head screw	3
58	01300634	SM010E01	Dancer-bar ASSY	1
59	01300644	ZV1#-GK4-0.35KW	Local Gearbox motor	1
60	----	GB/T 93-1987.8	8mm Spring washer	5
61	----	GB/T 70.1-2000.M8X30	M8x30 Hex socket head screw	4
62	01300637	SM010A07	Proximity switch mounting plate	2
63	01300007	TL-Q5MC1-Z	Proximity switch	2
64	01300638	SM010J05	Door cover stop	1
A	01300651	SM010J0702	Door guiding roller	1
B	01300652	SM010E0101	Dancer-bar pivot shaft	1
	01300653	SM010E0102	Dancer-bar roller	1
	01300654	GB/T 276-1994	61901-2Z bearing	2
	01300655	GB/T 894.1-1986.12	Circlip for shaft	2
	01300656	GB/T 893.1-1986.24	Circlip for hole	2

Note: No.1 (SM010J07) Door ASSY includes No.A (SM010J0702)

No.58 (SM010E01) Dancer-bar ASSY includes No.B (Dancer-bar parts)

8.2 Tower Drawing

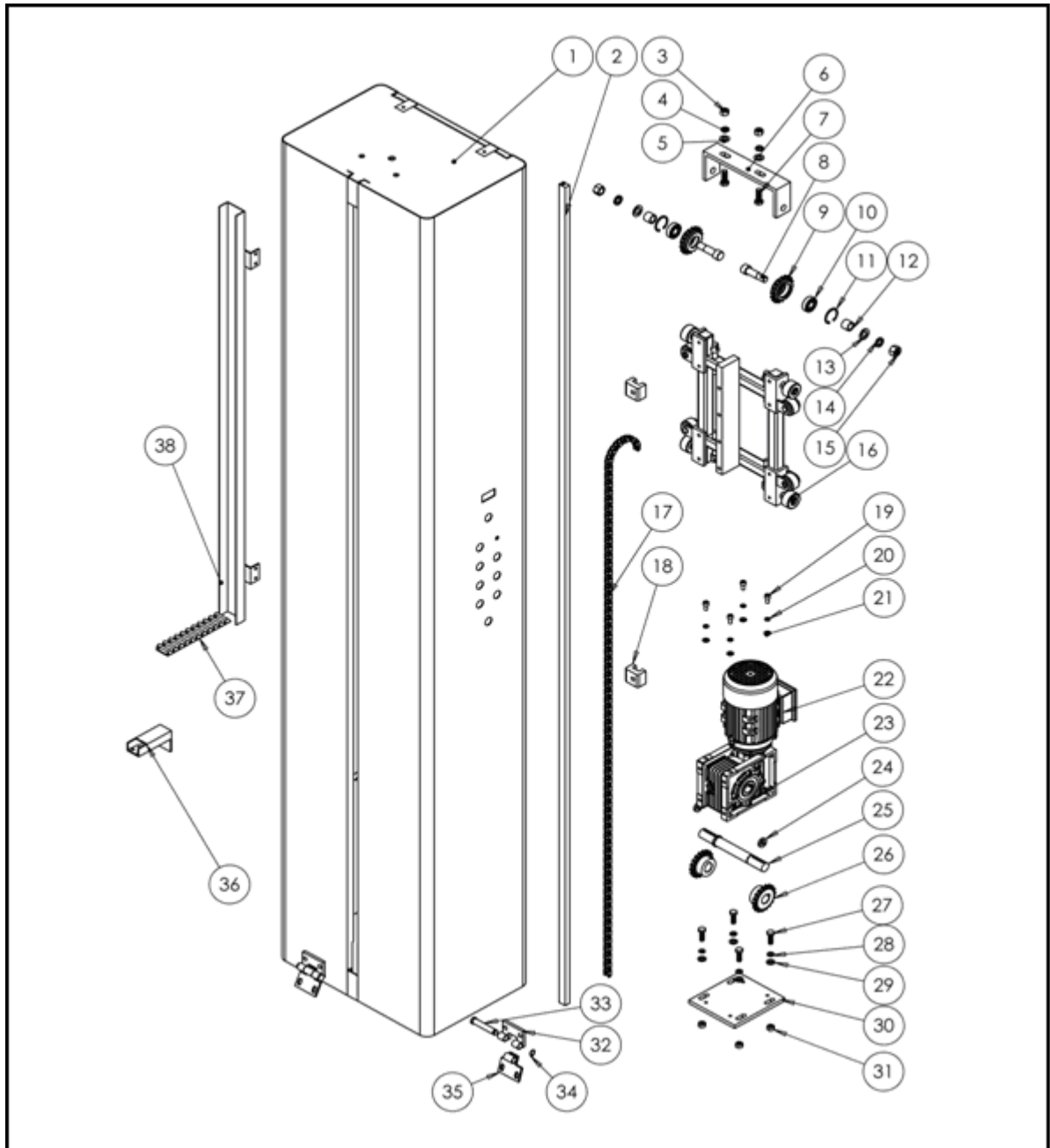

Tower part list SSIP0Z

No	Part No	ERP	Description	Qt
1	01300658	SSIP0Z01	Tower body	1
2	01300548	SSIP0W02	Aluminum slide way	1
3	01300503	GB/T 41-2000.M12	M12 Hex nut	10
4	01300504	GB/T 93-1987.12	12mm spring washer	2
5	01300505	GB/T 95-2002.12	12mm Flat washer	4
6	01300549	SS010A05	Sprocket bracket	1
7	01300550	GB/T 5783-2000.M12X40	M12x40 Hex bolt	2
8	01300552	SS010A07	Sprocket shaft	2
9	01300553	SS010A06	Sprocket B	2
10	005901	GB/T 276-1994	Deep groove ball bearing 6203-2Z	2
11	01300554	GB/T 893.1-1986.40	Internal circlip 40	2
12	01300555	SS050B06	Spacer sleeve	2
13	01300556	GB/T 95-2002.16	16mm Flat washer	2
14	----	GB/T 93-1987.16	16mm spring washer	2
15	01300557	GB/T 41-2000.M16	M16 hex nut	2
16	01300558	SSIP0C02A	Idler wheel carriage	1
17	01300559	GB/T 1243-1997	Chain 08B	2
18	01300560	SS010A1201	Limiting block	4
19	----	GB/T 5783-2000.M8x20	M8x20 Hex bolt	4
20	----	GB/T 93-1987.8	8mm spring washer	4
21	----	GB/T 95-2002.8	8mm Flat washer	4
22	01300561	7124B14-0.37-4	Motor	1
23	01300562	NMRV063-10071B14B3	Gearbox	1
24	----	SSIP0T08	Seat pad	2
25	01300563	NMRV063-DS25	Output shaft	1
26	01300477	CKZ-B2570T	Sprag clutch	2
27	----	GB/T 5783-2000.M10x30	M10x30 hex bolt	4
28	----	GB/T 93-1987.10	10mm spring washer	4
29	----	GB/T 95-2002.10	10mm flat washer	4
30	01300564	SS010A02	Gearbox motor bottom plate	1
31	----	GB/T 41-2000.M10	M10 Hex nut	4
32	01300565	SSIP0C05	Hinge seat B	2
33	01300566	SS020A01	Hinge shaft	2
34	----	GB/T 894.1-1986.14	14 Shaft circlip	2
35	01300567	SS020A02	Hinge seat A	2
36	01300640	SSIP0C03	Electric cable mount	1
37	01300571	TL18x25	Drag chain	1
38	01300572	SSIP0T02	Flat cable tray	1

8.2.1 Tower body drawing

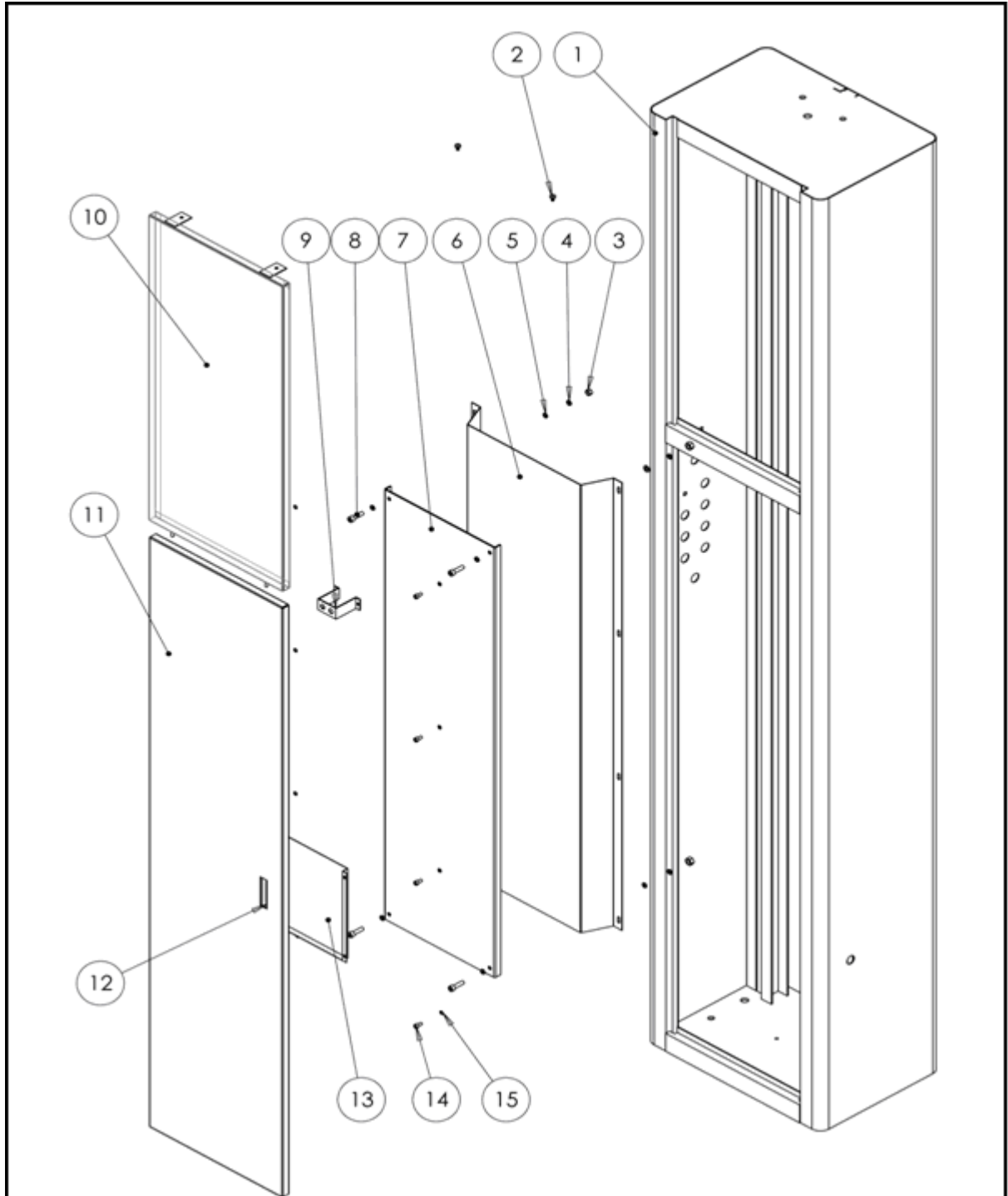

Tower body part list SSIP0Z01

No	Part No.	ERP	Description	Qty
1	01300659	SSIP0Z0101	Tower frame	1
2	----	GB/T818-2000.M6x10	M6X10 cross pan head screw H type	2
3	----	GB/T 41-2000.M8	M8 nut	4
4	----	GB/T 93-1987.8	8mm spring washer	4

5	----	GB/T 95-2002.8	8mm flat washer	8
6	01300540	SSIP0C0102	Inner protection panel	1
7	01300541	SSIP0C0103	Electric gear tray	1
8	----	GB/T 70.1-2000.M8x30	M8x30 hex socket head screw	4
9	01300542	SS010A0407	Knob switch bracket	1
10	01300543	SSRA0C0102	Top cover panel	1
11	01300544	SS010A0403	Electric cabinet door	1
12	01300249	SS010A0404	Door lock	1
13	01300545	SSIP0C0104A	Manual pocket	1
14	----	GB/T 70.1-2000.M6X12	M6x12 hex socket head screw	8
15	----	GB/T 95-2002.6	6mm Flat washer	8

8.2.2 Idler wheel carriage

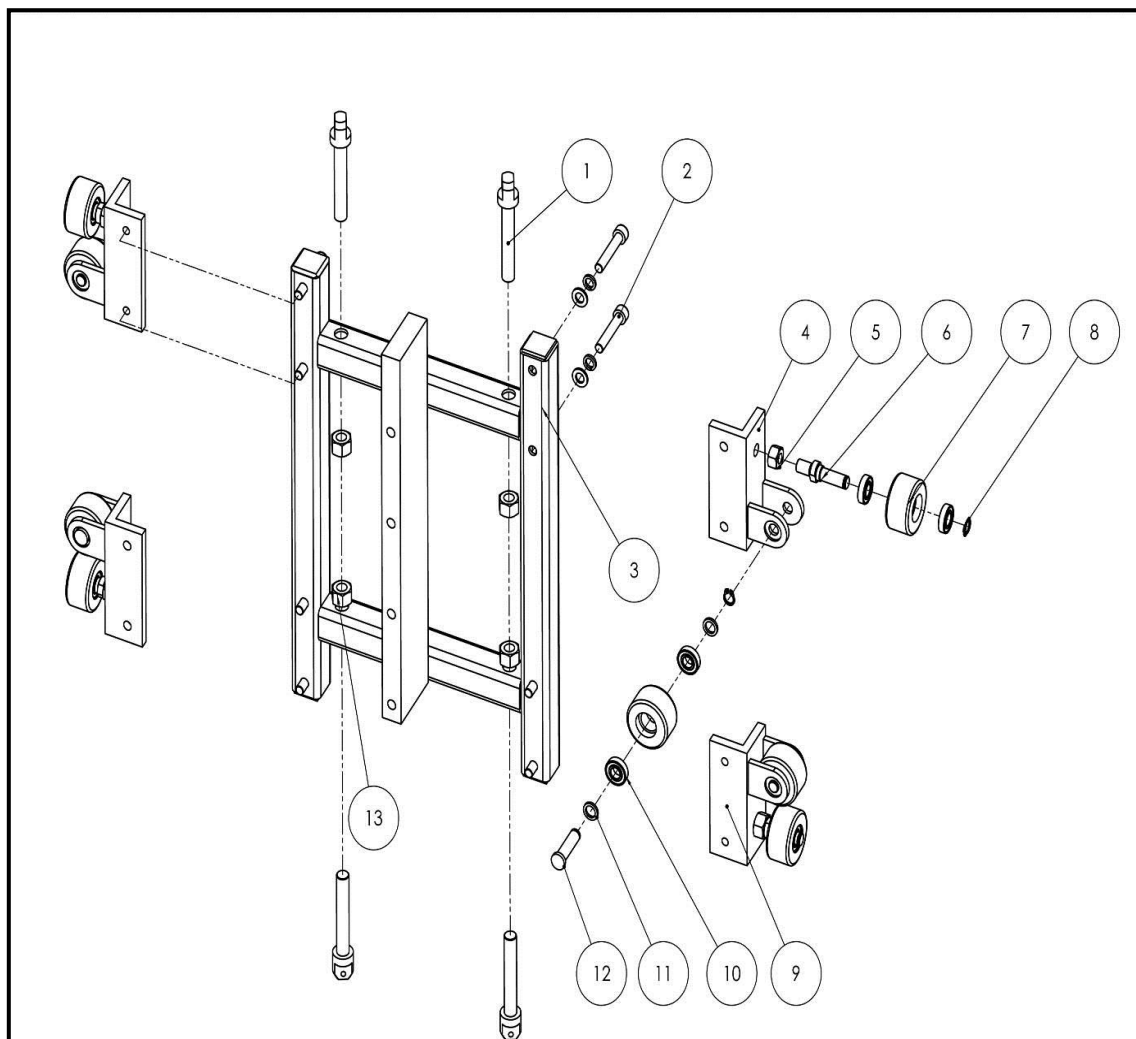

Idler wheel carriage part list SSIP0C02A

No	Part No.	ERP	Description	Qty
1	01300528	SS010A03	Chain adjusting bolt	4
2	----	GB/T70-1.M8x55	M8x55 hex socket head screw	8
3	01300529	SSIP0C0202A	Carriage body	1
4	01300530	SSIP0C020101	Idler wheel body	2
5	----	GB/T6170.M10	M10 nut	4
6	01300531	SSIP0C020105	Idler wheel shaft B	4
7	01300532	SSIP0C020103	Idler wheel	8
8	01300533	GB/T894-1.A10	Shaft circlip	4
9	01300534	SSIP0C020301	Idler wheel body	2
10	01300535	GB/T276.61900-2RS	Deep groove ball bearing	16
11	01300536	SSIP0C020104	Circlip	8
12	01300537	SSIP0C020102	Idler wheel shaft A	4
13	01300503	GB/T 41-2000.M12	M12 hex nut	8

8.3 Base Drawing

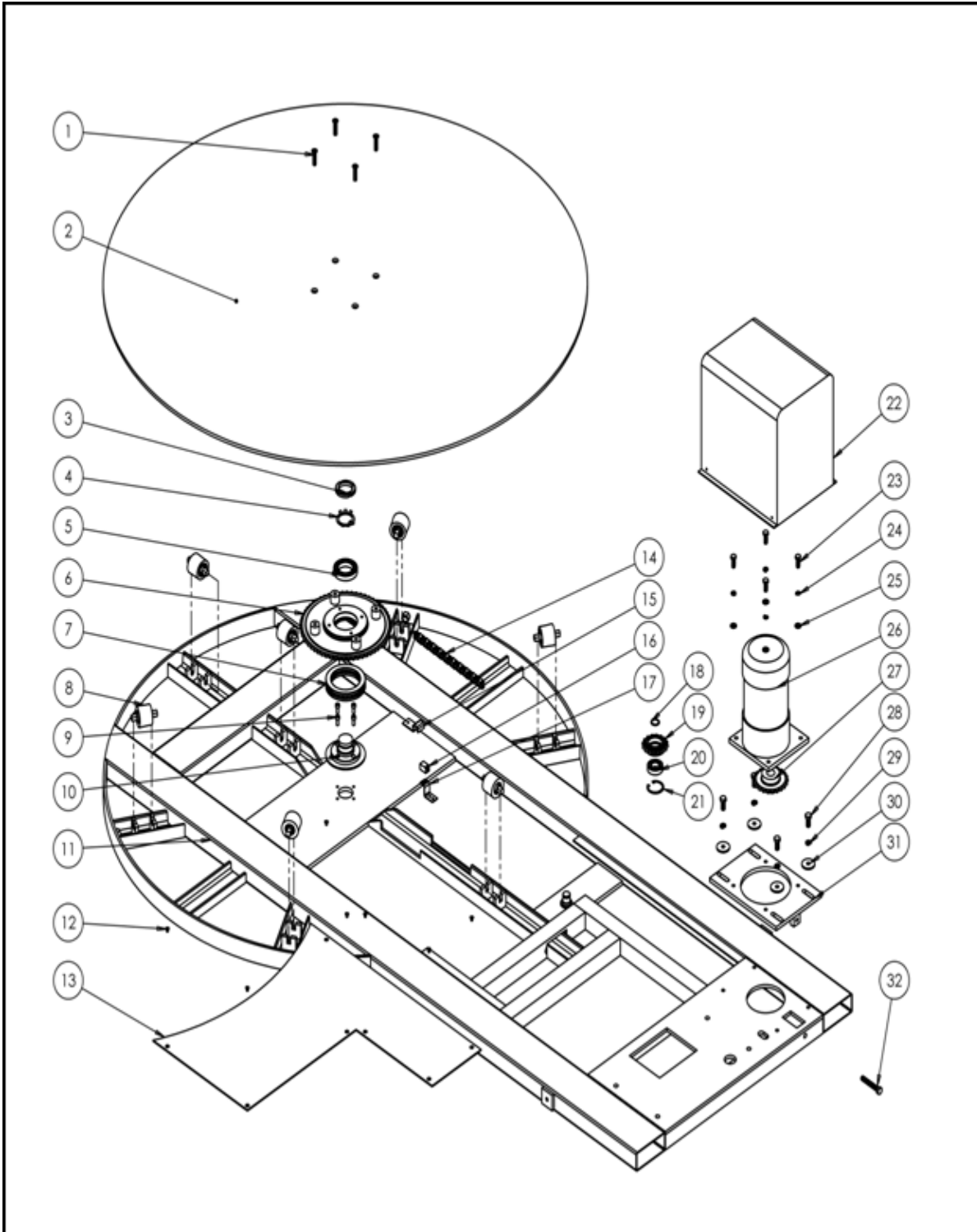

Base Parts List SZIP0S

No	Part No.	ERP	Description	Qty
1	----	GB/T 70.3-2000.M10x45	M10x45 hex socket countersunk head screw	4
2	01300573	SZ010A02	Turntable plate	1
3	01300452	GB/T 810-1988.M48x1.5	M48x1.5 lock nut	1
4	01300451	GB/T 858-1988.48	Lock washer 48	1
5	01300314	GB/T 276-1994	Deep groove ball bearing 6010-2Z	1

6	01300450	SZ010A03	Turntable drive sprocket	1
7	01300441	GB/T 301-1995	Thrust ball bearing 51120	1
8	01300206	SZ010A09	Turntable wheel	7
9	----	GB/T 70.1-2000.M8x20	M8x20 hex socket head screw	4
10	01300453	SZ010A04	Turntable pivot shaft	1
11	01300574	SZIP0C01	Base frame	1
12	----	GB/T 819.1-2000.M6x10	M6x10 cross recessed sunk screw H type	7
13	01300575	SZ010A07	Cover plate	1
14	01300576	GB/T 1243-1997	Chain 10A	1
15	----	SZ010A05	Sensor plate	1
16	01300007	TL-Q5MC1-Z	Proximity switch	1
17	----	SZ010A12	Bracket	1
18	01300577	GB/T 894.1-1986.25	25mm shaft circlip	1
19	01300578	SZ010A06	Idler Sprocket	1
20	01300579	GB/T 276-1994	Deep groove ball bearing 6205-2Z	1
21	01300580	GB/T 893.1-1986.52	52 Internal circlip	1
22	01300582	SZ010A08	Motor cover guard	1
23	----	GB/T 5783-2000.M10x30	M10x30 hex bolt	4
24	----	GB/T 93-1987.10	10mm spring washer	4
25	----	GB/T 95-2002.10	10mm flat washer	4
26	01300209	CV28-750-50SZ	Gearbox motor	1
27	01300583	SZ010A11	Sprocket	1
28	01300584	GB/T 5783-2000.M12X30	M12x30 hex bolt-full thread	4
29	01300504	GB/T 93-1987.12	12mm spring washer	4
30	01300585	GB/T 5287-2002.12	12mm Washer	4
31	01300586	SZ010A10	Gearbox mount plate	1
32	01300587	GB/T 5783-2000.M12x80	M12x80 hex bolt	1

9. STANDARD im WARRANTY

Standard 12 month warranty

Unless otherwise specified in the order/contract documents, Get Packed's warranty is 12 months single shift operation (2000) hours) from date of delivery.

The warranty covers parts and labour (subject to Clause 7 of the warranty conditions). All repairs are to be carried out by Get Packed or its authorised service agents.

Such warranty repairs shall be provided during normal working hours.

The warranty will only apply if the machine has at all times been operated within normal working values and in accordance with the manufacturers instructions. (This includes the regular scheduled and documented maintenance of the machine).

The conditions of the warranty are:

1. Applicable onto the the original purchaser from new and is not transferable.
2. The period of the warranty commences from the date of installation but is not enforceable until the final payment has been received.
3. That the machine operates in a dry, covered area and not in an aggressive environment.

This means free from:

Excessive dirt and dust
Corrosion
Moisture and condensation
Vibration

4. The machine has been installed to the manufacturers specifications.
5. The installation sheet has been properly completed and returned to Get Packed.
6. The machine service must be carried out by Get Packed or its authorised Agents to the specified maintenance schedule and logged.
7. The machine is located within a 100Km radius of Sydney.
Where the machine is located over 100Km from Sydney, Get Packed will charge a labour fee per hour based on the time spent outside the free service zone.
8. In any event, Get Packed's liability shall be limited to one of the following, at Get Packed's election - replacement of the defective goods, or the supply of equivalent goods, or the cost of repair of defective goods.

This warranty does not cover

1. Service calls, which are not related to any defect in the machine.
2. Correction to the installation or alterations of the machine.
3. Provision of training and or instructions on the use of the machine.
4. Replacement of fuses or resetting of circuit breakers.
5. Rectification of defects caused by other than normal industrial use for which the machine is designed.
6. Where contaminated or dirty air is supplied to the machine.
7. Repair of defect to the machine caused by accident, misuse or act of God.
8. Correction of improper repairs.
9. Normal recommended maintenance as set out in this machine operation and maintenance manual.
10. Return freight cost of suspected faulty components.
11. Special freight arrangements for the return of the repaired or replacement unit to the customers site.

Please Note:

The electrical control panel contains fragile components, it is important that suitable packaging be used when shipping back these components to Get Packed.

10. Safe Operating Guidelines

This pallet wrapper has been designed to package palletized loads with stretch film. The user is responsible for its safe and correct operation.

We recommend a 1 metre minimum clearance be maintained around the machine so that people do not become trapped by the rotating load.

This machine has been designed and fitted with forklift tine entry points for safe handling and movement. Please ensure that the machine is stable to move and that safe handling procedures are observed.

FILM LOADING

1. Place the film roll on the support mandrel, the outer, adhesive side will be applied onto the load.
2. Draw out approx. One metre of film clear of the film roll.
3. Pull enough film through rollers to attach to load.

SAFE OPERATION

1. Inspect load prior to wrapping to ensure pallet and load are stable.
2. Ensure that people and forklifts are clear of the load and machine.
3. Do not walk between the rotating load and the film carriage.
4. Wait for the machine to stop before cutting and wiping film tail.

If the film breaks or the load falls:

- stop the machine as necessary;
- restack the load so that it is stable on the pallet (where applicable) and re-attach the film; and then re-start the machine.

MAINTENANCE

The control switch contains live 240 volt electrical circuits capable of causing death upon contact. Therefore:

- (a) Only suitably qualified personnel should open and work inside.
- (b) The mains supply should be switched off and the lead safely disconnected from the socket before the following work is started:
 - cleaning of machine;
 - any other tasks where a hazard is created by electricity or the accidental start of the machine.

**IF YOU ARE UNSURE ABOUT ANY PROCEDURES, ASK
YOUR SUPERVISOR BEFORE COMMENCING**

These Safe Operating Guidelines have been developed from a Risk Assessment supplied by the manufacturer. They provide information relating to Occupational Health and Safety to machine users required by Victorian Plant Regulations 1995.