

PACKMATE R-WRAPPER

FLAT PACK ASSEMBLY INSTRUCTIONS

Step 1 During assembly, leave within open cardboard carton to avoid scratches. R-Wrapper frame must lay down as in the way it is carried with single 'carriage tube' **UP** as illustrated.

Step 2 Remove smaller cardboard wrap from Carriage and slide carriage right, towards pulley-end of frame.

Step 3 Remove and unwrap base and wheels from carton and keep nearby the 'wooden shipping-board' end.

Step 4 To remove the shipping board and while supporting the carriage tube weight: Undo two 13mm bolts with a spanner and the 6mm socket head bolt with an allen-key. Swap board with base and wheels and fasten bolts through base into frame tube ends. **Tighten 6mm 'Allen-key'** with spanner or tube for leverage. **Check frame tubes are parallel** before tightening 13mm bolts firmly when R-Wrapper is upright.

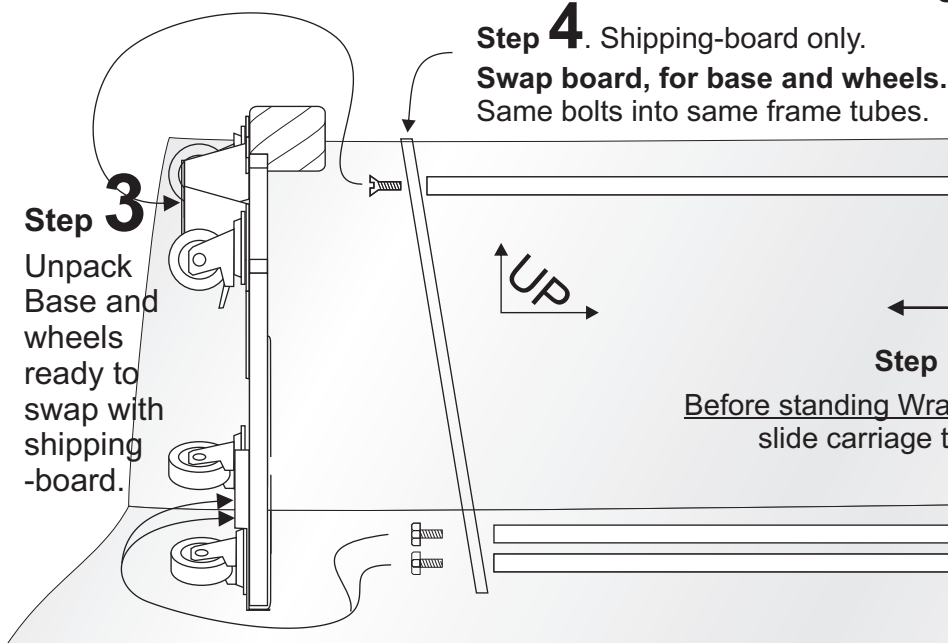

Step 4. Shipping-board only. Swap board, for base and wheels. Same bolts into same frame tubes.

Step 3 Unpack Base and wheels ready to swap with shipping-board.

Step 5. Before standing Wrappa up on wheels, slide carriage towards base.

PACKMATE R-WRAPPER

STEP 1: WHEEL THE R-WRAPPER TO THE PALLET TO DO THE JOB!

PACKMATE R-WRAPPER, MOBILE, ERGONOMIC PALLET WRAPPING. DESIGNED & MADE IN AUSTRALIA. SEE

Step 5 Slide Carriage toward base before standing R-Wrapper up on wheels to avoid carriage dropping down to the base

Step 6 Ensure lift rope is sitting in pulleys and not snagged around pulleys, carriage or any control handles then check operation. See INSTRUCTIONS FOR USE sheet for correct operation.

Step 2. Before unbolting shipping-board, Unwrap and **Slide carriage towards pulleys.**

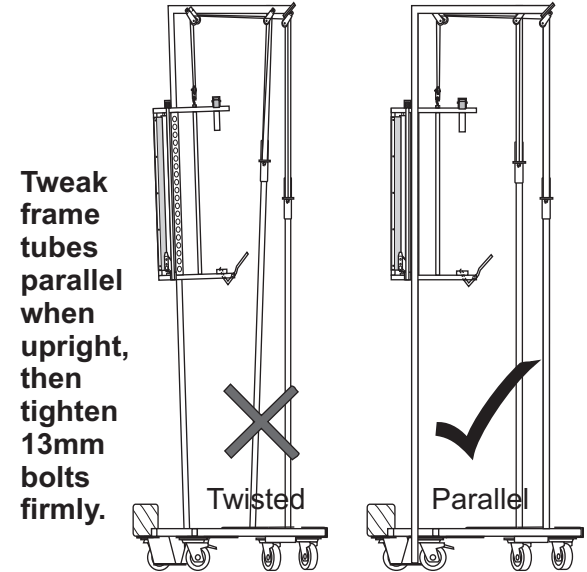

Tweak frame tubes parallel when upright, then tighten 13mm bolts firmly.

Twisted

Parallel

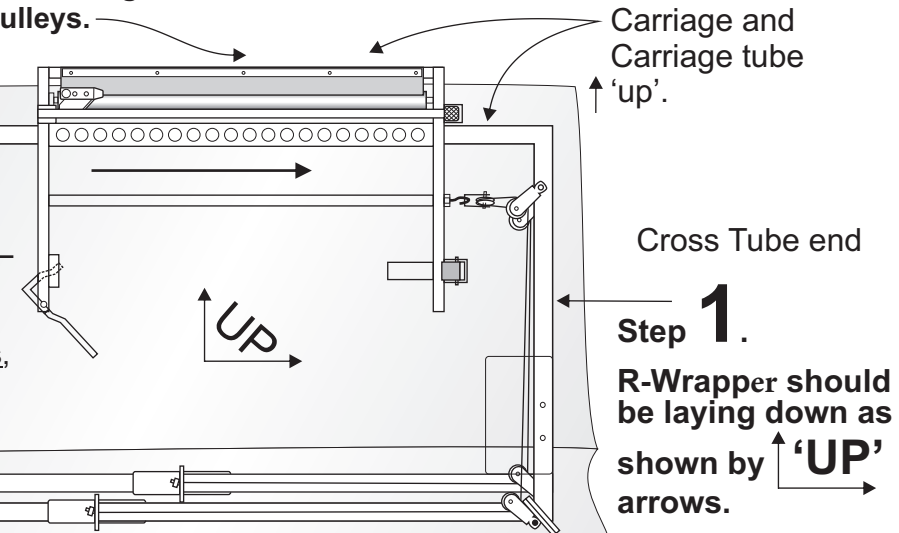

Carriage and Carriage tube 'up'.

Cross Tube end

Step 1. R-Wrapper should be laying down as shown by 'UP' arrows.

Assemble while in open cardboard carton to avoid scratches!



02 9452-3566
sales@getpacked.com.au